



AUTOMATIC ENTRANCE SPECIALISTS



**Cross14, Cross14E,
Cross14VE, Cross15V**

IP1732 - rev. 2005-03-10



- ① Manuale di installazione e manutenzione per automazioni per cancelli scorrevoli.
- ② Installation and maintenance manual for sliding gate automatic system.
- ③ Manuel d'installation et d'entretien pour automatisme pour portails coulissants.
- ④ Montage und Wartungshandbuch für Schiebetore Automatisierung.
- ⑤ Manual de instalaciòn y manutenciòn para automatizaciòn de cancelas de corredera.
- ⑥ Instalação e manutenção manual para portão correção sistema automático.



DITEC S.p.A.
Via Mons. Banfi, 3 - 21042 Caronno Pertusella (VA) - ITALY
Tel. +39 02 963911 - Fax +39 02 9650314
www.ditec.it - ditec@ditecva.com

ISO 9001
Cert. n° 0957/1

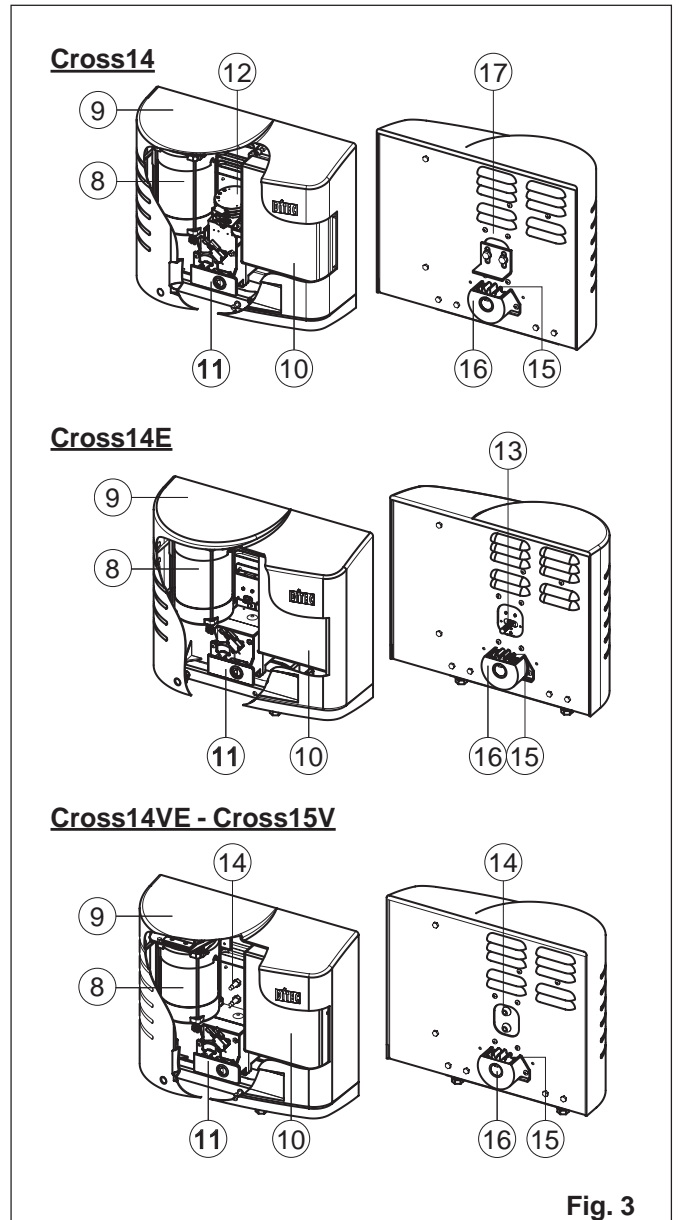
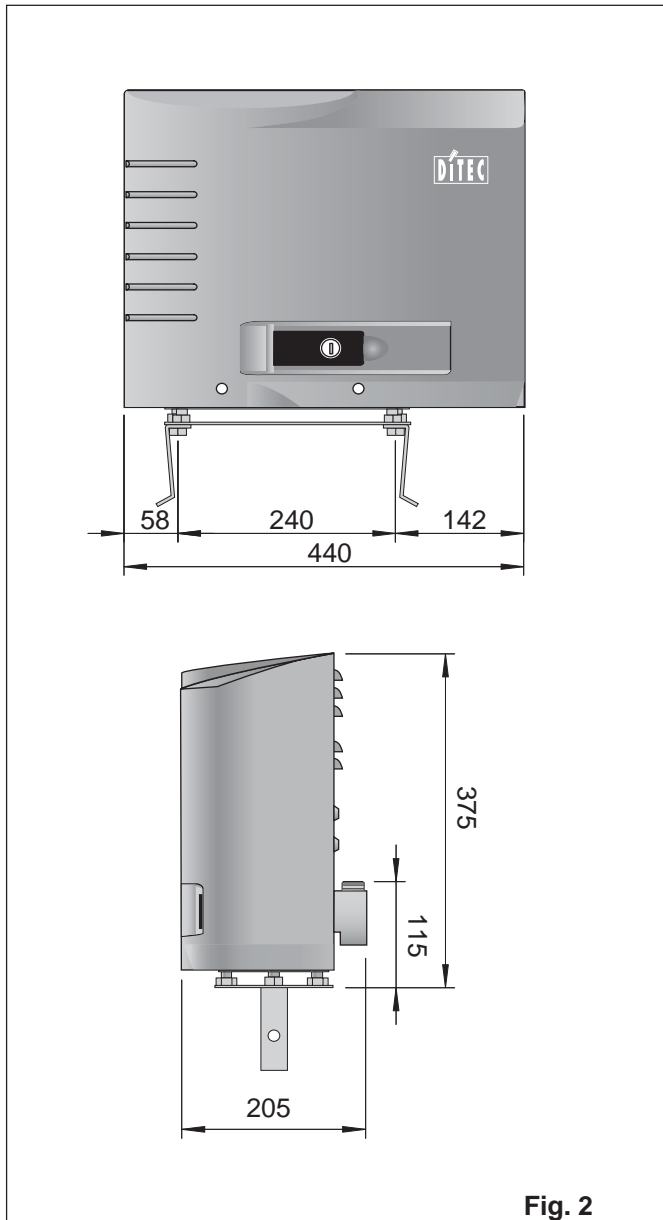
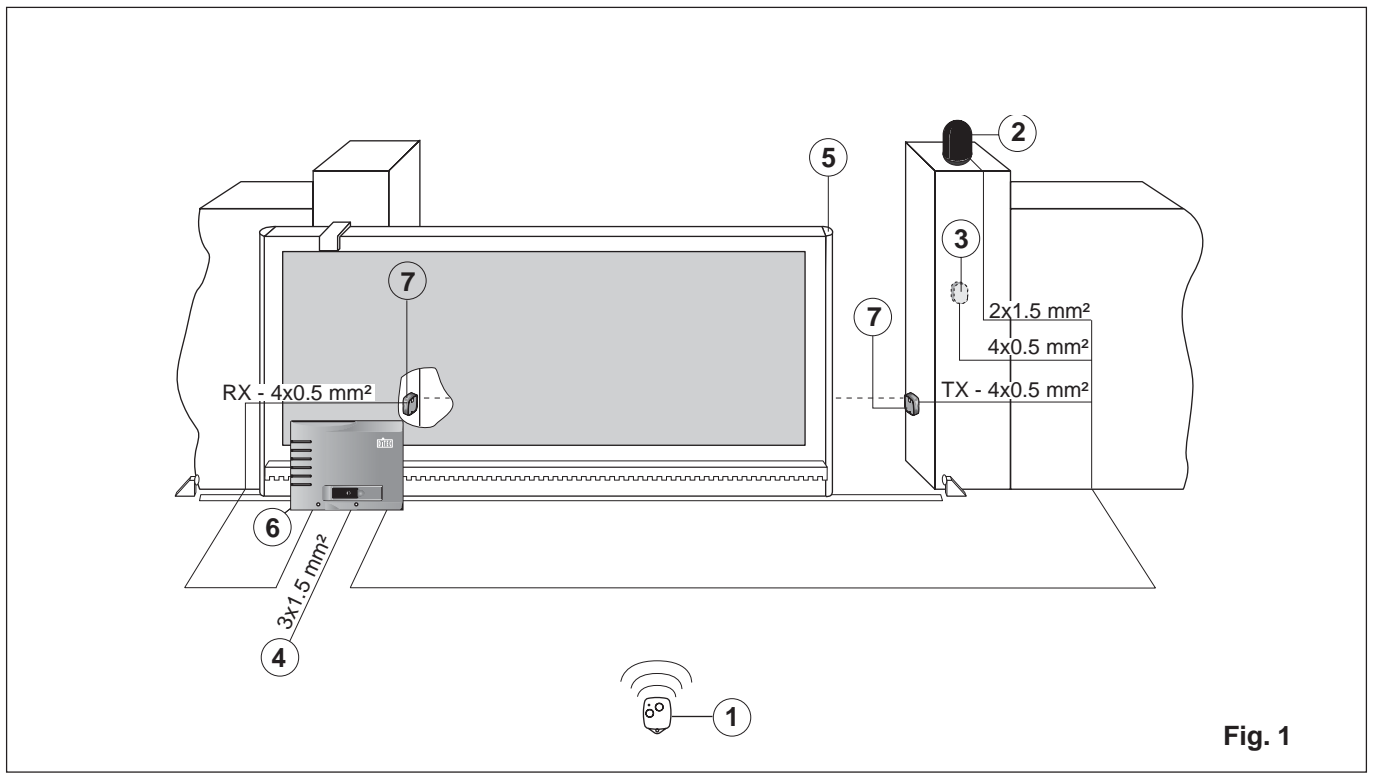

Cross 14

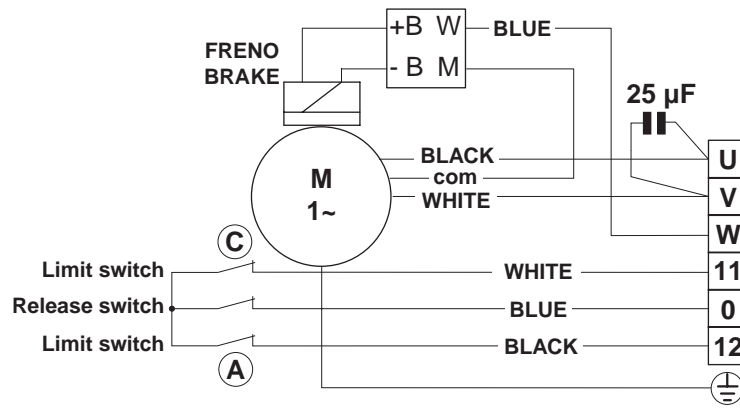

Fig. 4

Cross 14E - Cross 14VE

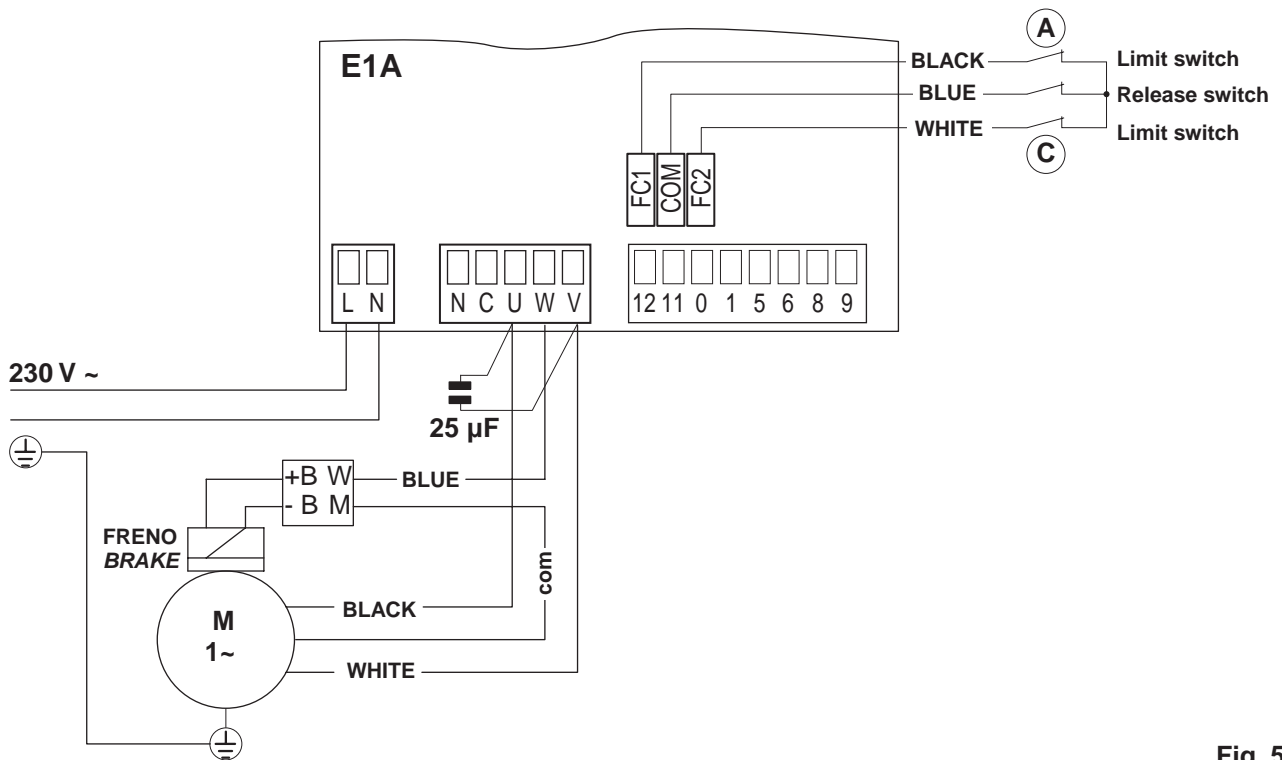

Fig. 5

Cross 15V

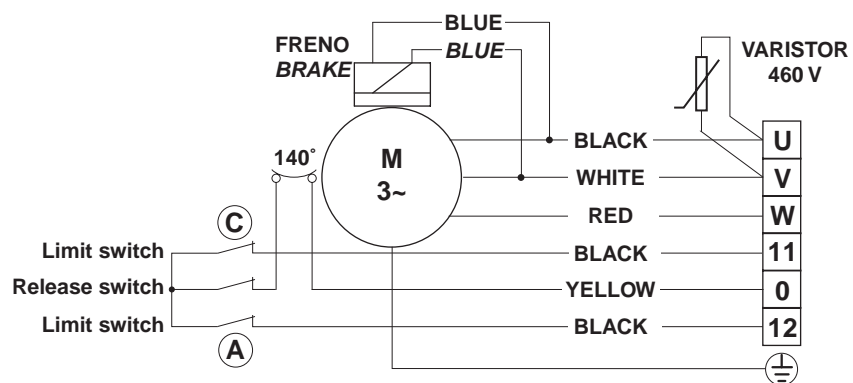

Fig. 6



GENERAL SAFETY PRECAUTIONS



This installation manual is intended for professionally competent personnel only.

Installation, electrical connections and adjustments must be performed in accordance with Good Working Methods and in compliance with applicable regulations.

Before installing the product, carefully read the instructions. Bad installation could be hazardous.

The packaging materials (plastic, polystyrene, etc.) should not be discarded in the environment or left within reach of children, as these are a potential source of hazard.

Before installing the product, make sure it is in perfect condition.

Do not install the product in an explosive environment and atmosphere: gas or inflammable fumes are a serious hazard risk. Before installing the motors, make all structural changes relating to safety clearances and protection or segregation of all areas where there is risk of being crushed, cut or dragged, and danger areas in general.

Make sure the existing structure is up to standard in terms of strength and stability.

The motor manufacturer is not responsible for failure to use Good Working Methods in building the frames to be motorised or for any deformation occurring during use.

The safety devices (photocells, safety edges, emergency stops, etc.) must be installed taking into account: applicable laws and directives, Good Working Methods, installation premises, system operating logic and the forces developed by the motorised door or gate.

The safety devices must protect any areas where the risk exists of being crushed, cut or dragged, or where there are any other risks generated by the motorised door or gate. Apply hazard area notices required by applicable regulations.

Each installation must clearly show the identification details of the motorised door or gate.



Before making power connections, make sure the plate details correspond to those of the power mains.

Fit an omnipolar disconnection switch with a contact opening gap of at least 3 mm. Make sure an adequate residual current circuit breaker and overcurrent cutout are fitted upstream of the electrical system.

When necessary, connect the motorised door or gate to a reliable earth system made in accordance with applicable safety regulations. During installation, maintenance and repair, interrupt the power supply before opening the lid to access the electrical parts.



To handle electronic parts, wear earthed antistatic conductive bracelets.

The motor manufacturer declines all responsibility in the event of component parts being fitted that are not compatible with the safe and correct operation.

For repairs or replacements of products only original spare parts must be used.

The installer shall provide all information relating to automatic, manual and emergency operation of the motorised door or gate, and provide the user with operating instructions.

MACHINERY DIRECTIVE

Pursuant to Machinery Directive (98/37/EC) the installer who motorises a door or gate has the same obligations as the manufacturer of machinery and as such must:

- prepare the technical file which must contain the documents indicated in Annex V of the Machinery Directive; (The techni-

cal file must be kept and placed at the disposal of competent national authorities for at least ten years from the date of manufacture of the motorised door);

- draft the EC declaration of conformity in accordance with Annex II-A of the Machinery Directive and deliver it to the customer;
 - affix the CE marking on the power operated door in accordance with point 1.7.3 of Annex I of the Machinery Directive.
- For more information consult the "Technical Manual Guidelines" available on Internet at the following address: www.ditec.it

APPLICATIONS

Service class: 4 (about 100 cycles a day for 10 years or 200 cycles a day for 5 years)

Use: INTENSIVE (For vehicle or pedestrian accesses to large condominiums, industrial or commercial complexes and parking lots with very frequent use).

- The operating performance specifications refer to the recommended weight (about 2/3 of maximum allowed weight). Use with maximum allowed weight could reduce the above performance specifications in technical data.
- The service class, operating times and number of consecutive cycles are merely approximate. These have been statistically determined in average conditions of use and are not certain for each single case. They refer to the period when the product operates without the need for special maintenance.
- Each automatic entrance features variable factors such as: friction, balancing and environmental conditions that can substantially change both the duration and operating quality of the automatic entrance or part of its components (including automatic system). It is up to the installer to adopt adequate safety coefficients for each single installation.

DECLARATION BY THE MANUFACTURER

(Directive 98/37/EC, Annex II, sub B)

Manufacturer: DITEC S.p.A.

Address: via Mons. Banfi, 3-21042 Caronno P.I.a (VA) - ITALY

Herewith declares that the electromechanical automatic system series Cross14-14E-14VE-15V.

- is intended to be incorporated into machinery or to be assembled with other machinery to constitute machinery covered by Directive 98/37/EC;
- is in conformity with the provisions of the following other EEC directives: Electromagnetic Compatibility Directive 89/336/EEC; Low Voltage Directive 73/23/EEC; and furthermore declares that it is not allowed to put the machinery into service until the machinery into which it is to be incorporated or of which it is to be a component has been found and declared to be in conformity with the provisions of Directive 98/37/EC and with national implementing legislation.

Caronno Pertusella, 14-10-2002

Fermo Bressanini
(Chairman)

1. TECHNICAL DETAILS	Cross14	Cross14E	Cross14VE	Cross15V
Power supply	230 V~ / 50 Hz	230 V~ / 50 Hz	230 V~ / 50 Hz	400 V~ / 50 Hz
Current	3 A	3 A	3 A	1.2 A
Motor power	350 W	350 W	350 W	450 W
Thrust	1200 N	1200 N	1200 N	1500 N
Speed	0.2 m/s	0.2 m/s	0.2 m/s	0.2 m/s
Max stroke	11 m	16 m	16 m	16 m
Max wing weight	1400 kg	1400 kg	1400 kg	1500 kg
Service class	4 - INTENSIVE	4 - INTENSIVE	4 - INTENSIVE	4 - INTENSIVE
Min. num. of consecutive cycles	50	50	50	50
Intermittency	S2=30min/S3=50%	S2=30min/S3=50%	S2=30min/S3=50%	S2=30min/S3=50%
Temperature	-20° C / +55° C	-20° C / +55° C	-20° C / +55° C	-20° C / +55° C
Degree of protection	IP54	IP54	IP54	IP54
Weight	19 kg	19 kg	19 kg	16 kg
Control panel	E1A	E1A*	E1A*	LogicT
Limit switch	ROTARY	LEVER	MAGNETIC	MAGNETIC

(*) Control panel installed on board.

2. REFERENCES TO ILLUSTRATIONS

The given operating and performance features can only be guaranteed with the use of DITEC accessories and safety devices.

2.1 Standard installation references (fig. 1)

- [1] Radio transmitter
- [2] Flashing light
- [3] Key selector
- [4] Connect power supply to an omnipolar switch with a contact opening gap of no less than 3 mm (not supplied by us).

Connection to supply mains must be carried out in an independent raceway separate from control connections and safety device connections.

- [5] Rubber edge / Sensitive edge
- [6] Gearmotor + Control panel (only Cross14E-14VE)
- [7] Photocells

2.2 Geared motor references (fig. 3,11,12)

- [8] Gearmotor
- [9] Casing
- [10] Control panel
- [11] Manual lock release
- [12] Rotatory limit-switch group
- [13] Lever limit-switch group
- [14] Magnetic limit-switch group
- [15] Pinion
- [16] Pinion casing
- [17] Rack guide bracket
- [18] Magnetic limit switch bracket
- [19] Lever limit switch bracket

2.3 Accessories

- Cross CRI** Galvanized steel rack
- Cross TC** Chain drive kit
- Cat1** Chain 1/2" (5 m)
- CatG** Coupling for 1/2" chain

3. INSTALLATION

Unless otherwise specified, all measurements are expressed in millimetres (mm).

3.1 Preliminary checks

Check for gate stability (derailment and sideways falling), that the slide wheels are in good condition and that the top guides do not cause any friction.

The sliding track must be securely anchored to the ground and fully exposed along its full length.

It must be perfectly smooth so as to avoid jamming of the gate. Provide opening and closing stops.

N.B.: Make sure that the gate is securely inserted in the slideway so that it cannot come out of the slideway and fall.

In case of slits being present on the gate, cover them to avoid any risk of cutting.

To reduce impact force installation of safety devices at gate ends is recommended

3.2 Base plate prearrangement

- Insert the anchoring brackets into the base plate and secure them by means of the nuts provided.

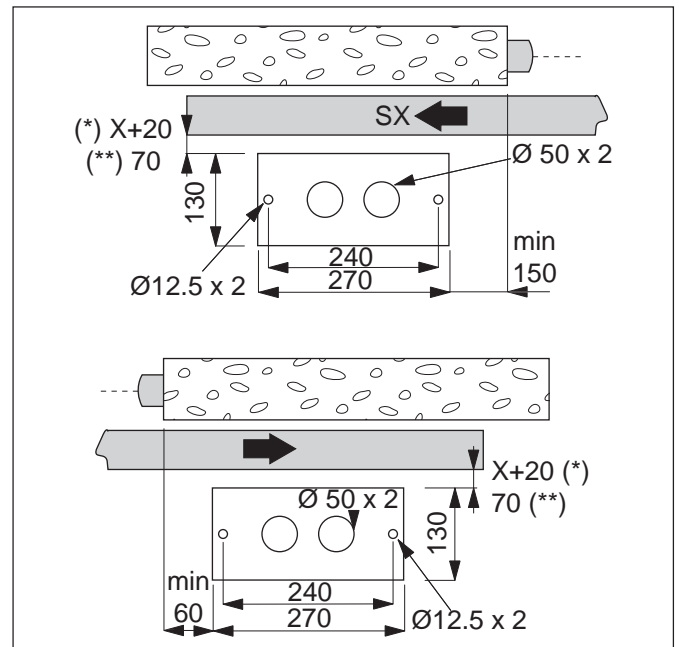
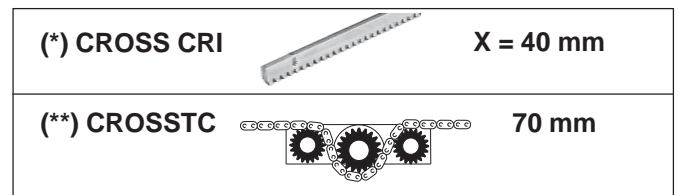

Lay a concrete foundation with buried anchoring brackets and the base plate, making sure it is perfectly levelled and smooth, complying with the measurements shown in figure.

If a concrete foundation is already available, secure the base plate by means of appropriate dowels (not supplied by us) so as to allow height adjustment.

- Route the cable ducts through one of the two holes in the middle of the plate.

3.3 Geared motor installation

- Release the gearmotor and remove the key. Loosen the two frontal screws and remove the casing [9].
- Position the gearmotor onto the base plate.
- Gearmotor adjustments

Horizontally by making gearmotor slide along the anchoring brackets notches (max 10 mm). Vertically with the 4 levelling screws [F]

N.B.: While adjusting vertically, keep the motor slightly raised above the base plate so as to allow enough space to secure the rack and to make any subsequent adjustments, if necessary.

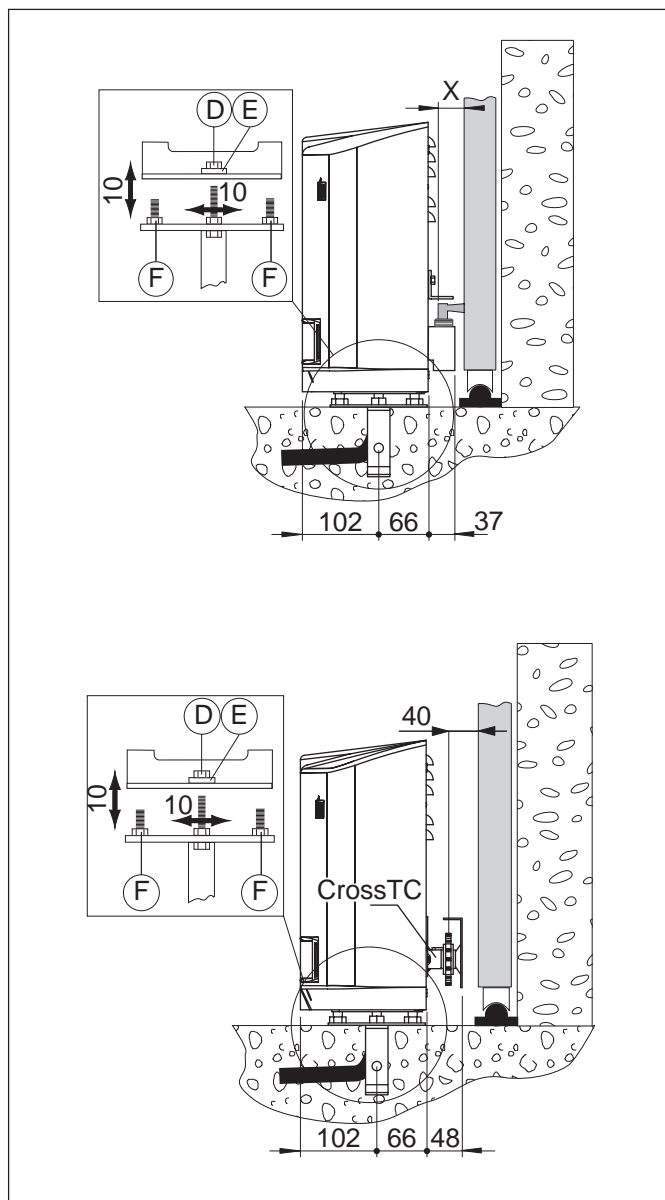

3.4 Rack installation

- Release the gearmotor (see OPERATING INSTRUCTIONS) and set the gate in the open position. Place the rack on the pinion [15] and move the gate manually to secure the rack along its full length.
- Once the rack has been secured, vertically adjust the gearmotor so as to have a gap of 2 - 3 mm between the pinion and the rack and a gap of approximately 3 mm between the rack and the rack guide bracket (only Cross14).

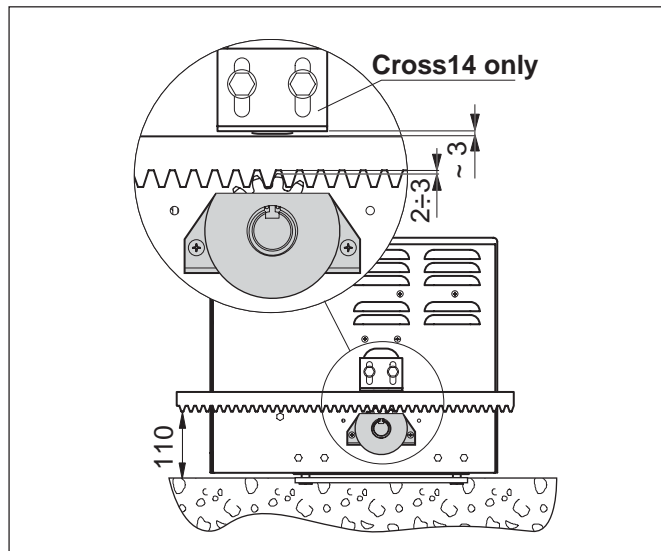

- Firmly secure the gearmotor by means of nuts [D].
- Lubricate the rack and pinion lightly after assembly. Manually move gate to check that it slides freely and smoothly.

3.5 Lever limit switch adjustment

- Manually position the door wing completely open and fasten the limit switch brackets [19] onto the rack so that the lever limit switch exceeds the bracket's length by approximately 2/3. Repeat the operation with door wing completely closed.
- After having performed a certain number of operations, adjust the position of the limit switch bracket [19] so that the gate will stop about 20 mm before the opening and closing stops.

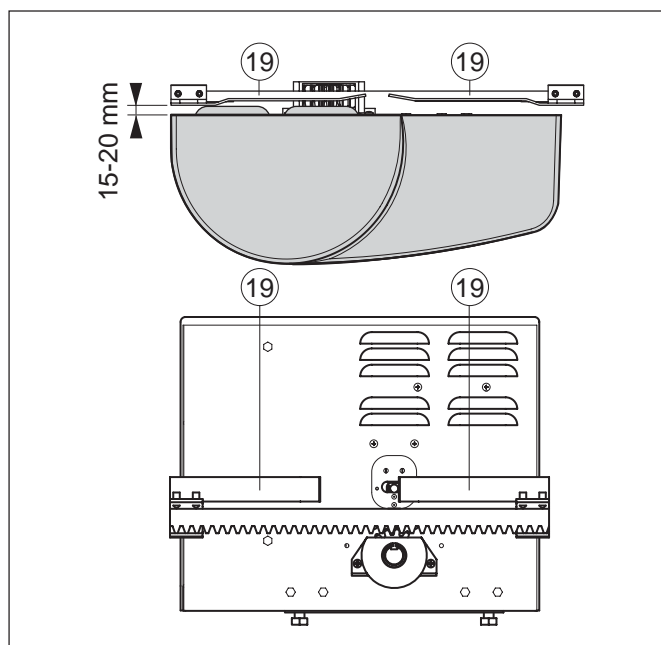

3.6 Magnetic limit switch adjustment

- Manually position the door wing completely open and fasten the limit switch brackets [18] onto the rack so that the lever limit switch exceeds the bracket's length by approximately 2/3. Repeat the operation with door wing completely closed.
- After having performed a certain number of operations, adjust the position of the limit switch bracket [18] so that the gate will stop about 20 mm before the opening and closing stops.

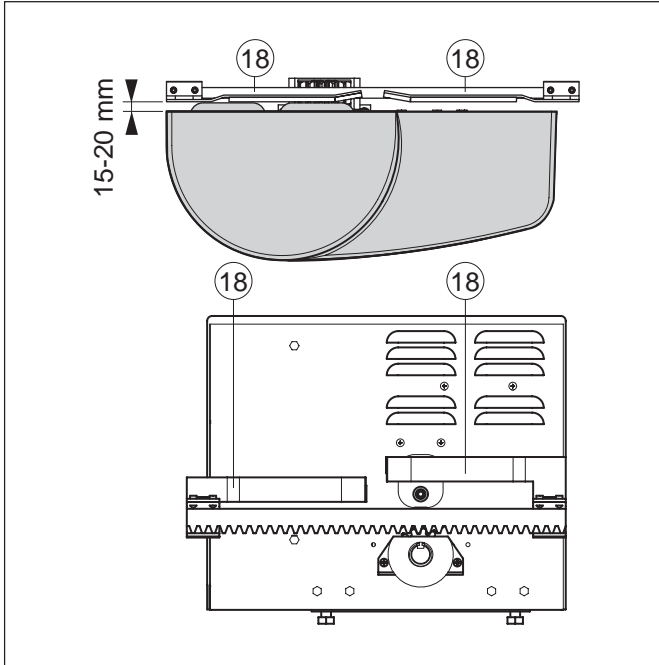
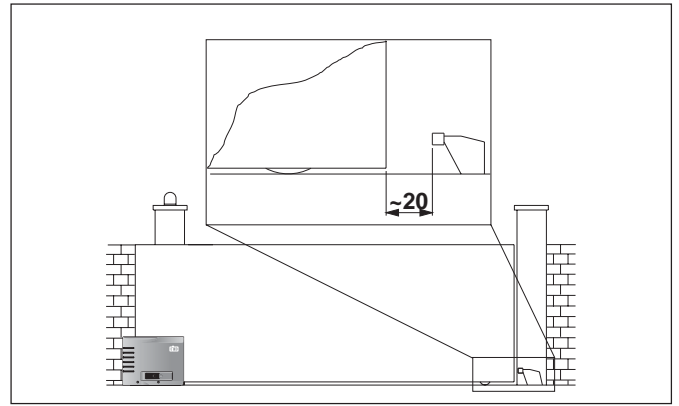

3.7 Rotatory limit switch adjustment

- With the gate open, turn screw [A] so that cam [M] activates the opening microswitch. With gate closed, turn screw [C] so that cam [L] activates the closing microswitch.
N.B. : For gates that open on the left-hand side (garmotor side view), the limit stop microswitches are inverted [A] for closing and [C] for opening.
- Adjust [A] and [C] so that the limit switches trip cut off the motor about 20 mm before the gate reaches the gate stops.
N.B.: Check this is still happening after having performed a certain number of operations.

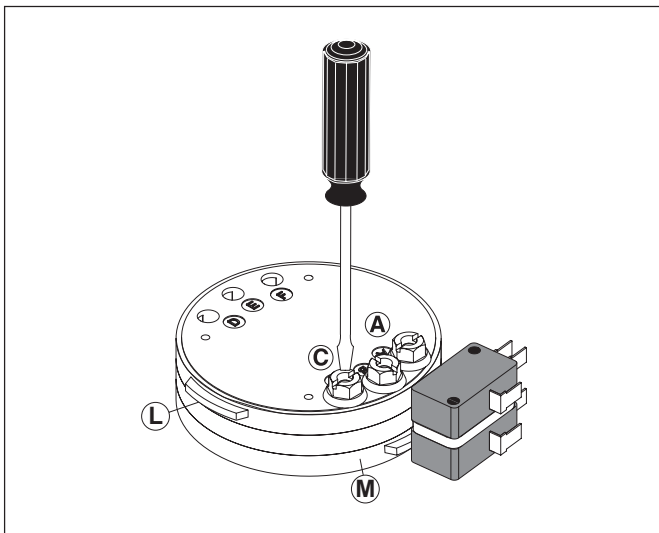

GB 3.8 CrossTC INSTALLATION for Cross 14 (for Cross 14)

Disengage the gearmotor (see OPERATING INSTRUCTIONS). Remove the pinion [15] and the rack guide bracket [17]. Fix the pinion-holding plate to the gearmotor. Fit the pinions as shown in the figure. Manually route the chain through the pinions. Fix the cover plate.

Attention: With chain fitted, the gearmotor direction of rotation is reversed.

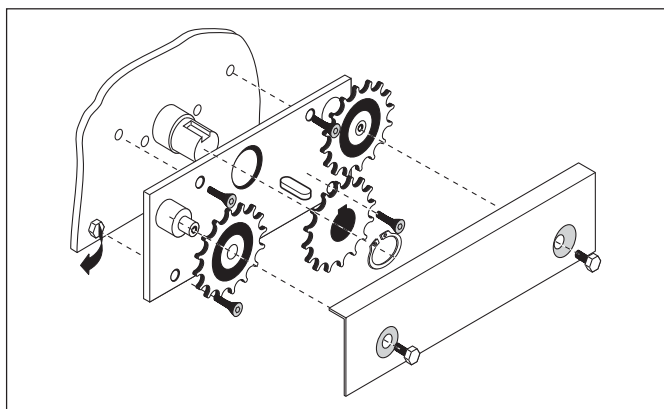

3.9 Chain installation

- Set the gate in the open position and fasten brackets [G] to the wing as shown in figure.

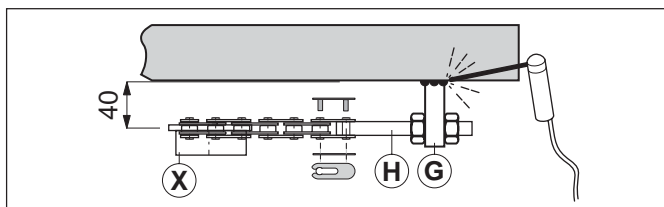

- Connect the chain previously installed on the gearmotor to the tie rod [H] and fasten it to the bracket [G].
- Secure the bracket [G] onto the opposite side of the gate. Connect the chain to the tie rod [H] and secure it to the bracket [G] (cut off excess chain).

With the gate in complete opening and closing position, check that the distance between the centre of the pinion [X] and the tie rod [H] shown in figure is respected.

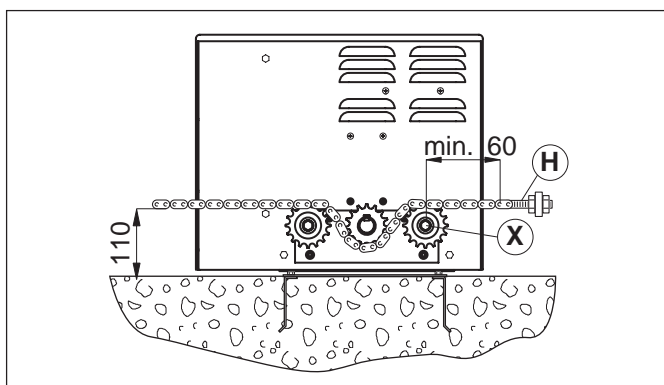

- Finally, firmly secure the gearmotor by means of nuts [D].
- Tighten the chain by means of tie rods [H].
- Lightly lubricate the chain and pinion after assembly.

4. ELECTRICAL CONNECTION

Electrical wiring and starting are shown in the installation manual of Control Panel E1A.

Attention: for motor's and limit-switch connection, see figure 4, 5, and 6.

WARNING: connect the yellow-green ground cable to the clamp already connected to the motor, as it is shown in the figure.

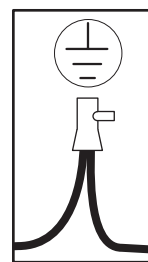

5. MAINTENANCE PROGRAM (each 6 month)

Power off and geared motor released (see OPERATING INSTRUCTIONS):

- Visually check that the gate, anchoring bracket and existing structure are sufficiently sturdy and in good condition.
- Check gate/gearmotor alignment and the distance (2-3 mm) between the mouth of the pinion and the crest of the rack and check the distance from the rack to the rack guide bracket (3 mm), if fitted.
- Clean the wheel sliding tracks, lightly lubricate the pinion, the rack or the chain. Manually move gate to check that it slides freely and smoothly.

Power on and geared motor lock (see OPERATING INSTRUCTIONS):

- Check the functioning of the limit switches (the gate must come to a halt about 20 mm before the stops).
- Check the power adjustments.
- Check the operation of all controls and safety functions.

ATTENTION: For spare parts, see the spares price list.



RELEASE INSTRUCTION

In case of fault or power failure, insert and turn the key anticlockwise, completely open the cover. Manually open the gate. To lock the gate again, shut the cover, turn the key clockwise and remove the key .

Attention: Perform locking and lock release operations with motor cut off.

Attention: With the cover closed and the key in a horizontal position, the lock release microswitch is open, thus preventing any operation.

GENERAL SAFETY PRECAUTIONS

The following precautions are an integral and essential part of the product and must be supplied to the user. Read them carefully as they contain important indications for the safe installation, use and maintenance.

These instruction must be kept and forwarded to all possible future user of the system.

This product must be used only for that which it has been expressly designed.

Any other use is to be considered improper and therefore dangerous.

The manufacturer cannot be held responsible for possible damage caused by improper, erroneous or unreasonable use. Avoid operating in the proximity of the hinges or moving mechanical parts.

Do not enter the field of action of the motorised door or gate while in motion.

Do not obstruct the motion of the motorised door or gate as this may cause a situation of danger.

Do not lean against or hang on to the barrier when it is moving. Do not allow children to play or stay within the field of action of the motorised door or gate.

Keep remote control or any other control devices out of the reach of children, in order to avoid possible involuntary activation of the motorised door or gate.

In case of breack down or malfunctioning of the product, disconnect from mains, do not attempt to repair or intervene directly and contact only qualified personnel.

Failure to comply with the above may create a situation of danger.

All cleaning, maintenance or repair work must be carried out by qualified personnel.

In order to guarantee that the system works efficiently and correctly it is indispensable to comply with the manufacturer's indications thus having the periodic maintenance of the motorised door or gate carried out by qualified personnel.

In particular regular checks are recommended in order to verify that the safety devices are operating correctly. All installation, maintenance and repair work must be documented and made available to the user.

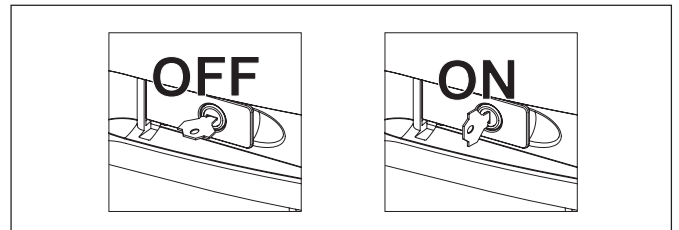
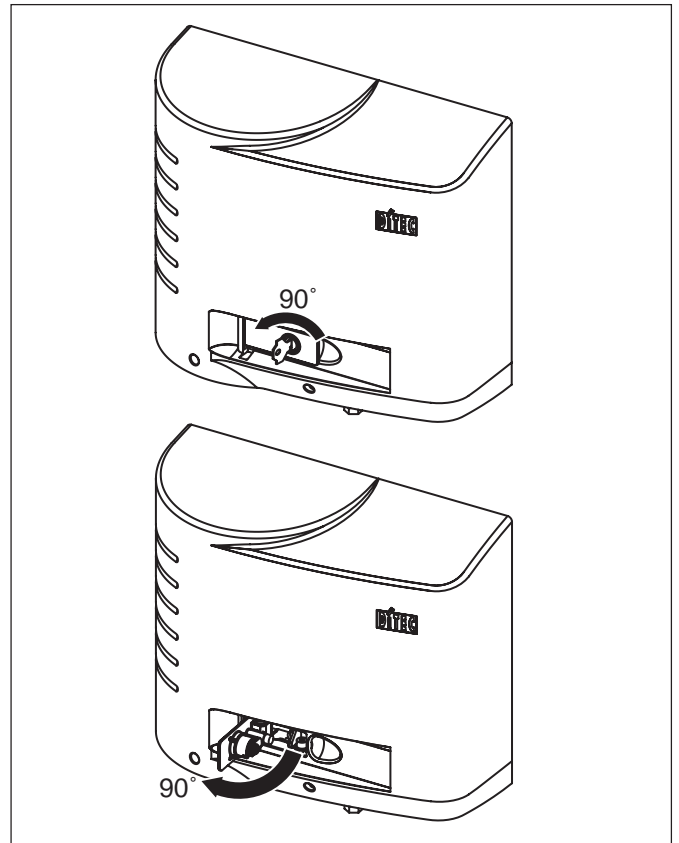

TEAR OFF AND DELIVER TO USER



DITEC S.p.A.
Via Mons. Banfi, 3
21042 Caronno Pertusella (VA) - ITALY
Tel. +39 02 963911 - Fax +39 02 9650314
www.ditec.it - ditec@ditecva.com

Installer:

Empty rounded rectangular box for installer signature.

DITEC S.p.A.

Via Mons. Banfi, 3
21042 Caronno P.IIa (VA)
ITALY

Tel. +39 02 963911
Fax +39 02 9650314

www.ditec.it
ditec@ditecva.com



Quarto d'Altino (VE)



Caronno Pertusella (VA)

DITEC BELGIUM

LOKEREN

Tel. +32 (0)9 356 00 51
Fax +32 (0)9 356 00 52

www.ditecbelgium.be



Lokeren



Oberursel

DITEC DEUTSCHLAND

OBERURSEL

Tel. +49 6171914150
Fax +49 61719141555

www.ditec-germany.de



Palaiseau



Mendrisio

DITEC FRANCE

PALAISEAU

Tel. +33 1 64532860
Fax +33 1 64532861

www.ditec.fr

DITEC SVIZZERA

MENDRISIO

Tel. +41 91 6463339
Fax +41 91 6466127

www.ditecswisse.ch

DITEC AMERICA

ORLANDO - FLORIDA - U.S.A.

Tel. +1 407 8880699
Fax +1 407 8882237

www.ditecamerica.com



Orlando

